

Roslyn

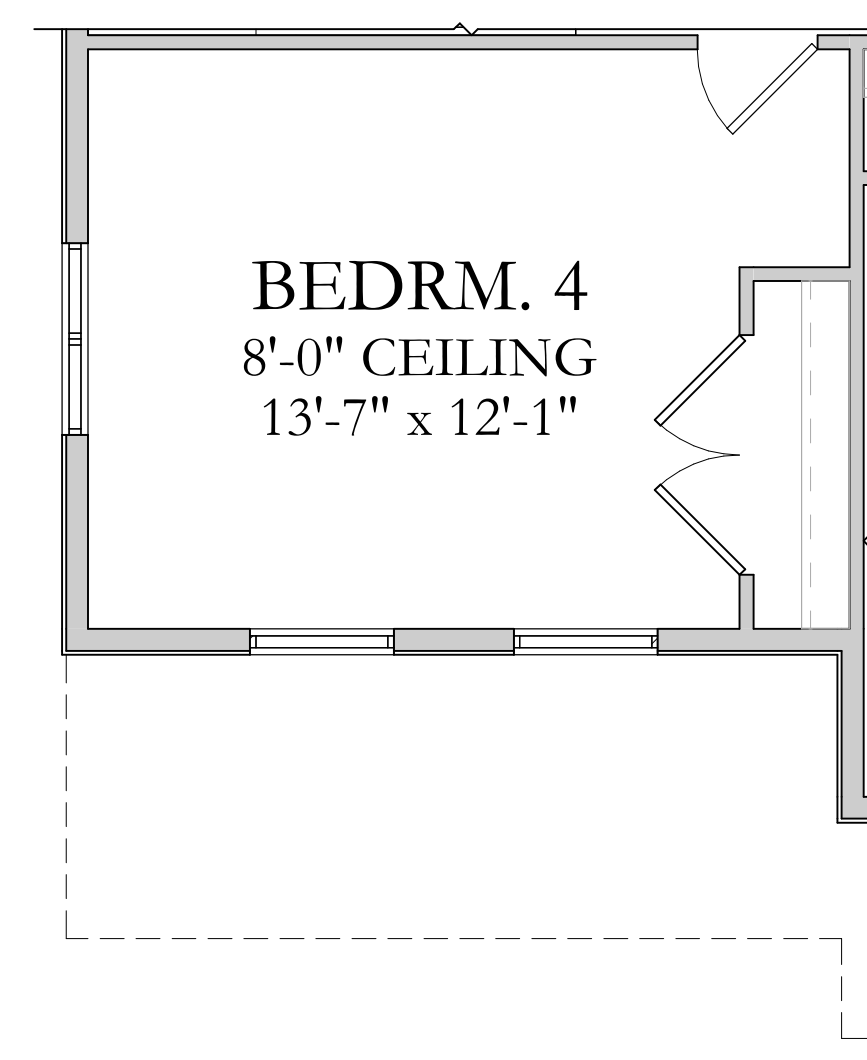

OPTIONAL 4TH BEDRM.

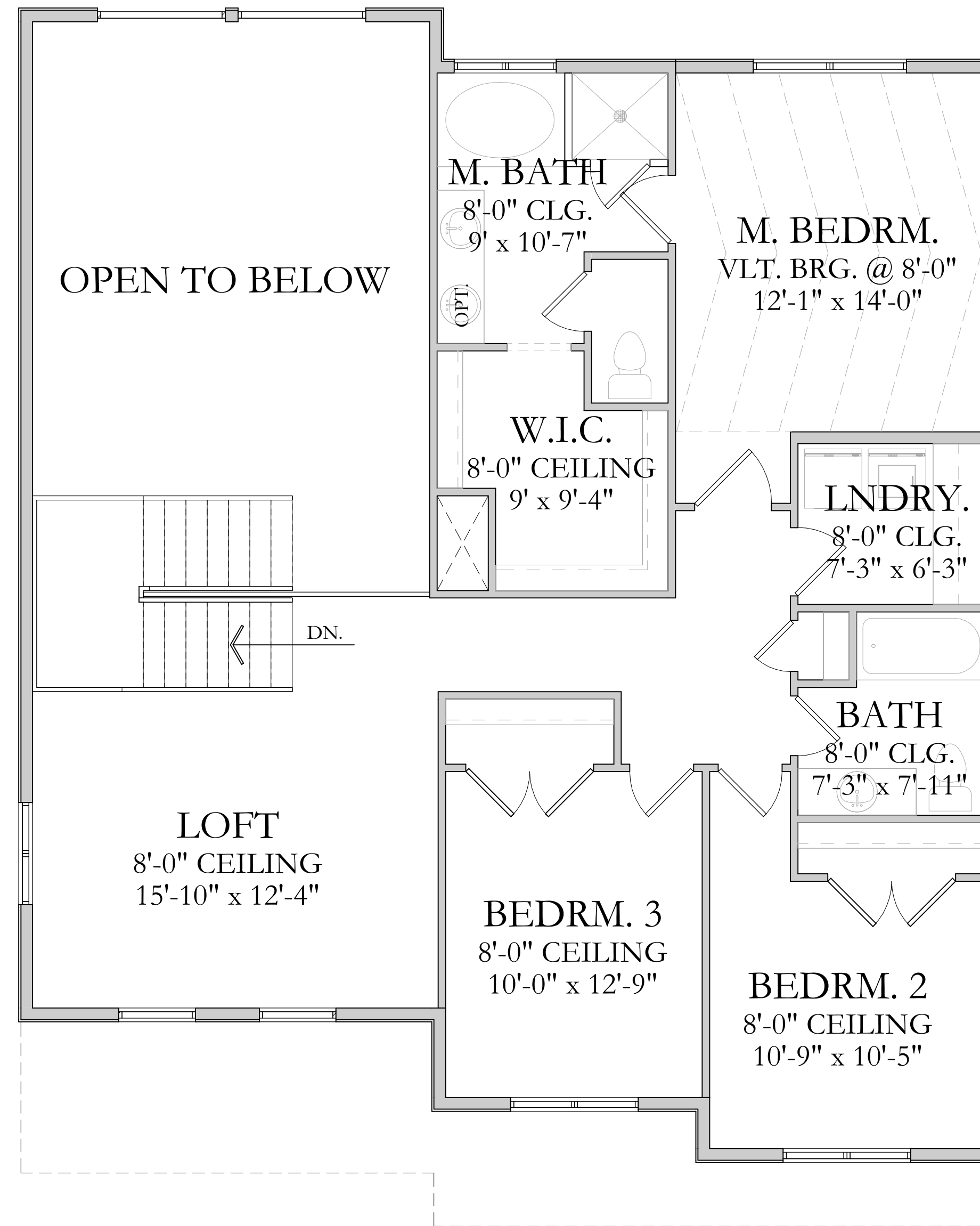

UPPER LEVEL

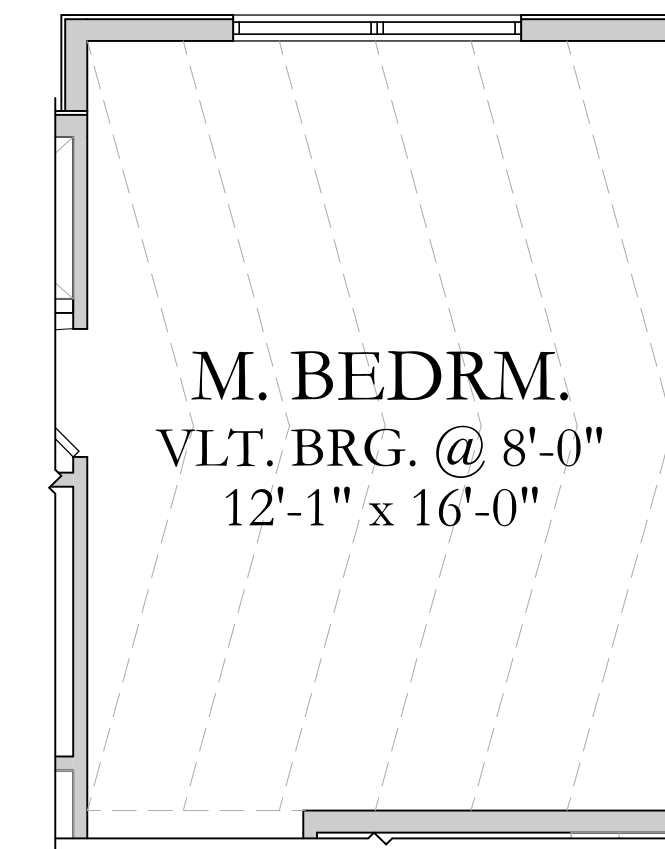

OPTIONAL MASTER POP-OUT
(ADDS 26 SQFT TO UPPER LEVEL)



Square Footage:

BASEMENT:	1278 SQFT
MAIN FLOOR:	1170 SQFT
UPPER FLOOR:	1240 - 1266 SQFT

Total Square Footage:

TOTAL FINISHED:	2410 - 2436 SQFT
TOTAL:	3688 - 3714 SQFT
WIDTH:	38'-2" TO 50'-2"
DEPTH:	47'-7" TO 49'-7"

Disclosure: Home SQFT--both finished and unfinished--are approximate and are subject to change. Please see sales agent for further information.